



Model C6-200
**SMALL
ANIMAL
CREMATORY**



*The next generation...
from a leading maker of Animal Crematories*

All the features you've been looking for!

- ⇒ Single batch load capacity up to 200 lbs. of carcass.
- ⇒ Easy loading 29 in. height for heavy animals.
- ⇒ No visible emissions or odors; EPA compliance.
- ⇒ Save fuel... Temperature Controller cycles primary burner on/off.
- ⇒ Easy to use... Set timers and walk away.
- ⇒ Thick high temperature refractory lining throughout... Extends equipment life.
- ⇒ Available with either Natural Gas or LPG burners.

**LOWEST EQUIPMENT OPERATING COST IN THE
INDUSTRY!**

Designed specifically for...

**Veterinarians
Humane Societies
Small Animal Control**

Distributed By:

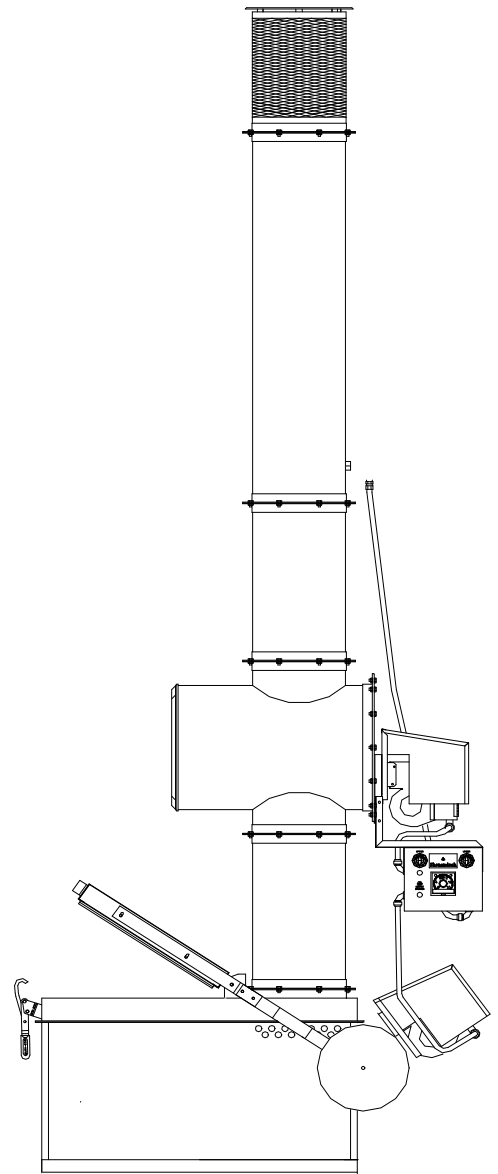

C6-200

Benefits and Features of the C6-200

Fast, complete, efficient waste disposal

- ⇒ Concave refractory bottom specifically designed to insure burnout and total destruction of liquid wastes.
- ⇒ Secondary chamber and insulated, refractory-lined stacks for emissions control.

Minimum installation and start-up time

- ⇒ Factory assembled, aluminized steel jacket lined with high-temperature refractory.
- ⇒ Recorders and accessory equipment available.

Easy and safe operation

- ⇒ Counter-balanced fill door.
- ⇒ Timer control system for each burner provides preset burn times and automatic shut off.

Low energy consumption levels

- ⇒ Temperature control maintains temperature, assuring complete combustion while conserving fuel.
- ⇒ Choice of fuels: LP or natural gas.

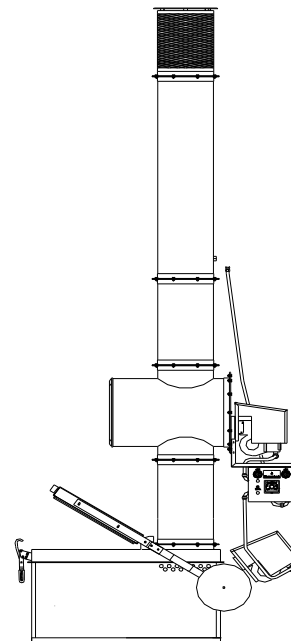

Specifications Summary

C6-200-LP Propane-Fired Cremation System complete with two burners, secondary chamber, stack, timers, and temperature control
C6-200-N Natural Gas-Fired Cremation System complete with two burners, secondary chamber, stack, timers, and temperature control

WASTE CHAMBER

Chamber capacity (Type 4 waste-pathological)	200 lbs	90.5 kg
Chamber volume (approximate)	6 cu. ft.	1.85 cu. m.
Chamber size (outside)	Width 26" Height 32" Length 42"	66 cm 91 cm 107 cm
Door opening	18" x 20"	46 cm x 51 cm
Height to door	29.5"	856 cm
Height to top of secondary chamber	7'-1"	2.2 m
Overall dimensions (w/stack)	18'H x 33"W x 51"L	4.9m x 83.8cm x 129.5cm
Suggested slab size (l x w x thick)	10' x 12' x 6"	3.0 m x 3.7m x 15cm

STACK

Dimensions (OD)	14"	36 cm
Material	14 gauge Aluminized Steel Jacket, refractory lined	

REFRACTORY THICKNESS

Primary	3.0"(2800F)	7.6 cm
Secondary	1.5"(2800F)	3.8 cm
Stack	1.5"(2800F)	3.8 cm

	C6-200-LP	C6-200-N
APP. FUEL CONSUMPTION	LP	NATURAL GAS
	6.65 GPH	610 CFH
APPROXIMATE BTUH		
Upper burner	480,000	480,000
Lower burner	240,000	260,000

INSTALLATION

Must be installed in accordance with local codes and ordinances, subject to regulatory agencies. Outside installation is recommended with a simple metal roof or three-sided metal shelter, providing a minimum of four foot clearance from any combustible roof materials. Minimum of 18" clearance is required for penetration of combustible roof materials. Inside installations may have special insurance requirements. Factory must be advised.

GENERAL

Electrical service
 Standard – 115 volt, 60 HZ, 20 amp
 Also available – 220 volt, 50 HZ, 10 amp

BURNERS

LP or Natural gas burner with spark ignition and flame safety shut-off.

OPERATION

2 manual timers

TOTAL WEIGHT

3000 lbs. (approximate) 1361 kg

* Fuel consumption approximate. Actual fuel use depends on BTU content of waste. Consult factory for retention times or special requirements